

PERMANENT COPY

1934-E

Parker Duofold

SERVICE MANUAL

Parker Duofold

SERVICE MANUAL

A COMPLETE COURSE
IN SERVICING
PARKER DUOFOLD
FOUNTAIN PENS



THE PARKER PEN COMPANY
JANESVILLE, WIS., U.S.A.

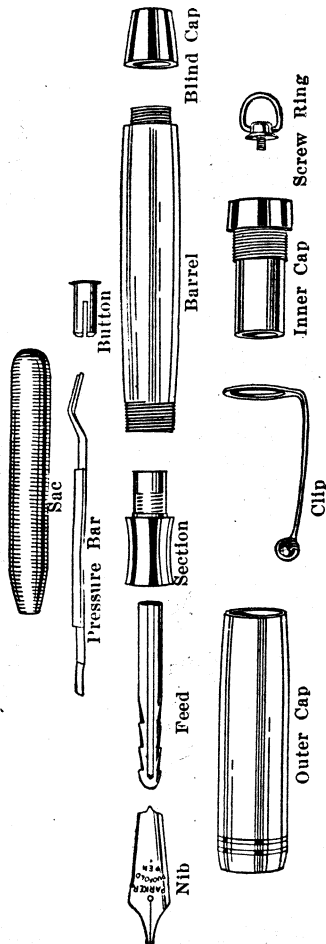

THE COMPONENT PARTS OF A PARKER DUOFOLD FOUNTAIN PEN AND THE MATERIALS THEY ARE MADE OF

Sac	Soft Rubber
Pressure Bar	Metal; Spring Bar: Phosphor bronze, Small Plate: Nickel Alloy
Button	Brass, gold plated
Gold nib	14 Karat gold, tip of Iridium
Feed	Hard Rubber
Section	Hard Rubber
Barrel	Permanite (a very highly refined pyroxylin product)
Blind Cap	Hard Rubber
Outer Cap	Permanite and 2 rolled gold bands
Clip or Screw Ring	Rolled Gold
Inner Cap	Hard Rubber

TO TAKE PEN APART

Remove the blind cap and pull out the button by using a metal plate in which a small indentation has been cut or filed.

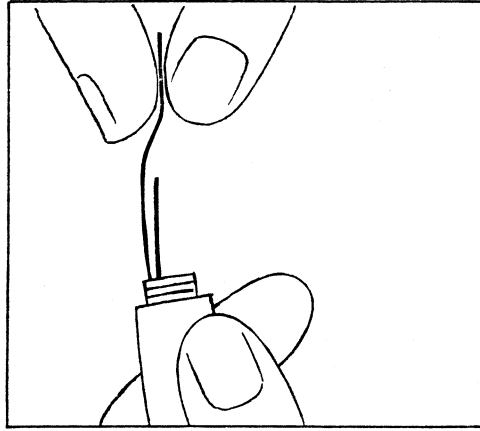
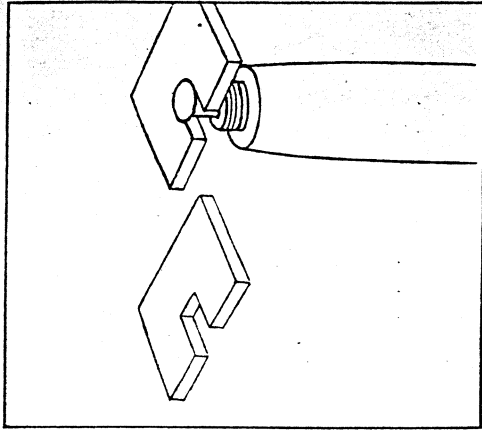

Now remove pressure bar, pulling it out carefully.

Straight shaped pens have a screw-section; streamlined pens are fitted with a slip-section. Before removing section from barrel, tap the barrel at the threads with a blunt tool or hit the barrel against the edge of a table; this will loosen the shellac which was used in fitting the section. Then with a piece of rubber (cut from a wide rubberband) grip the section tightly. If it is a screw section, unscrew it; if it is a slip section, pull it out with a rocking motion.

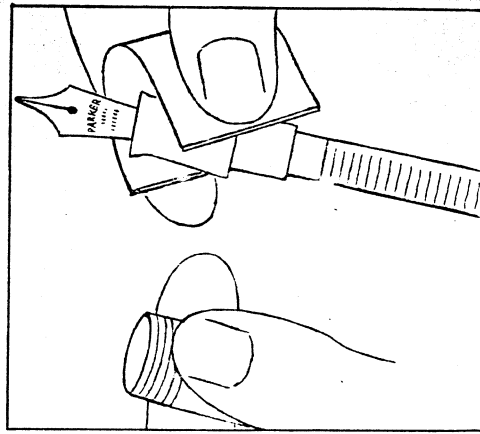

TO REMOVE GOLD NIB

This operation varies according to the type of feed used in the fountain pen. Feed A has a curve at the bottom and cannot be pulled out from front of section. Feed B has no curve and can be pulled out from front. The latter can be recognized by a small notch on the under side of the feed.

If pen has feed A, grasp the gold nib firmly between thumb and finger and move it back and forth until it becomes loose in section and can be pulled out.

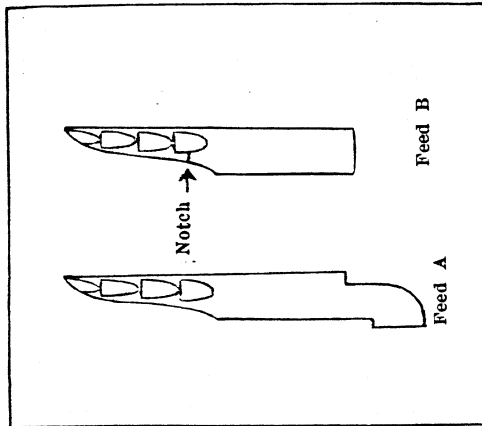

If pen has feed B, use a pair of pliers with a piece of rubber tubing in its mouth. Insert nib and feed into rubber tubing as far as possible, close jaws of pliers and extract nib and feed.

Be sure to use rubber tubing with pliers or you will spoil the gold nib.

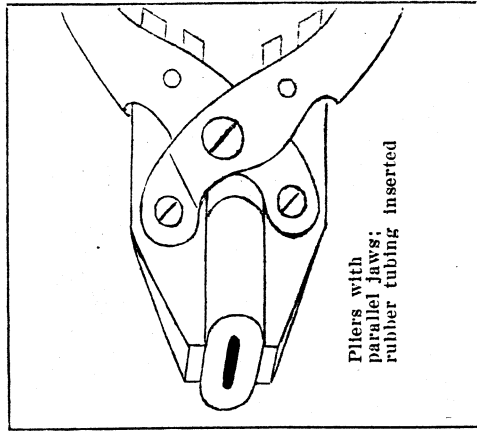
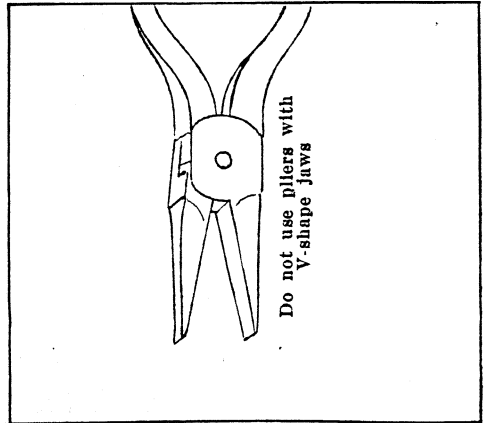

Only pliers, the jaws of which are parallel when open, can be used for this operation. Do not attempt to do this with pliers which open in V-shape, because you will ruin feed and gold nib.

If a gold nib is fitted too tightly, so that it cannot be extracted as directed above, pass section over a small flame a few times. This softens the section and makes removal of nib easier. After a section has been heated it must be rolled between fingers until it cools, so that it will not lose its shape.

TO FIT A GOLD NIB

With feed A: Insert the gold nib into the front of the section and the feed into the rear of the section; push both in as far as you can with your fingers. Then, hold the nib firmly between fingers, place curve of feed against edge of table and press with force until nib and feed reach correct position.

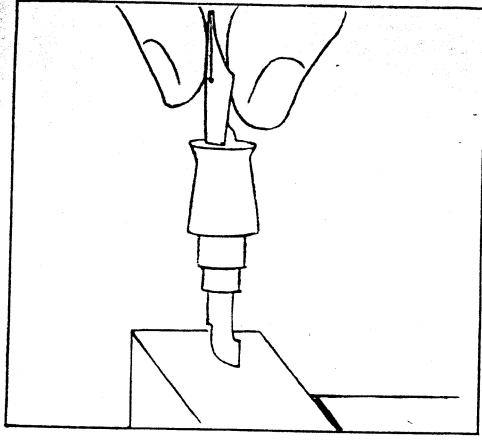

With feed B: The feed with a notch on underside is fitted from front of section. Place gold nib over feed in correct position and grasp both with pliers fitted with rubber tubing; push both nib and feed into section of pen until lettering on the gold nib is about one-quarter inch from section.

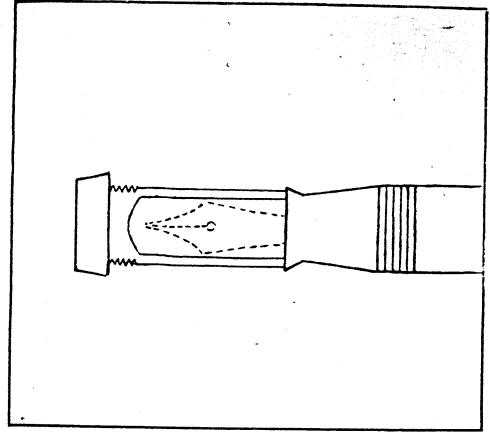
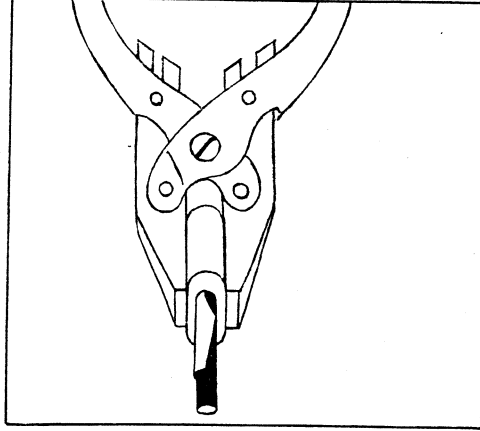

After nib is fitted it must be tested with the inner cap to see if it is inserted deep enough (see illustration). If the nib touches the upper wall of the inner cap, it must be fitted deeper, or it will be ruined when the cap is screwed on.

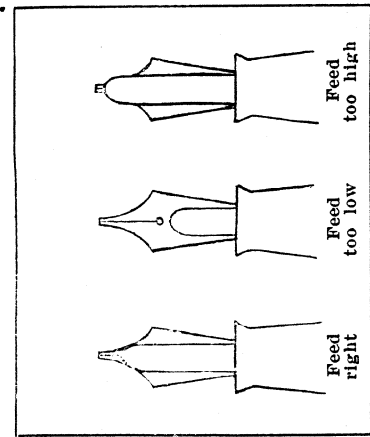

The channel of the feed has two indentations, one on each side, through which ink is attracted to the writing point by capillary action.

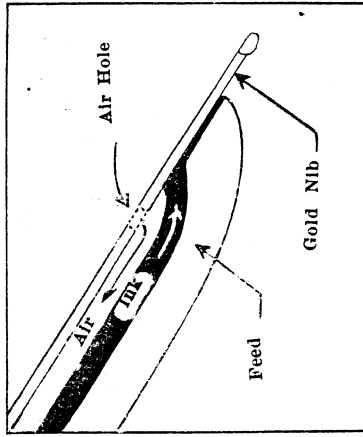

The smooth flow will take place only when the gold nib fits closely against feed, as in A. Ink is under control because it is confined to ink channel. When a space is left between nib and feed, ink will fill the space and destroy the action of the channel, with the result that the volume of ink and its rate of flow is left out of control. See B.

TO ADJUST THE FEED

Make sure the feed is adjusted correctly.

When feed is fitted too low, ink does not reach the nib evenly and pen will not write properly.

When feed is adjusted too high, ink will flow too freely and blot.

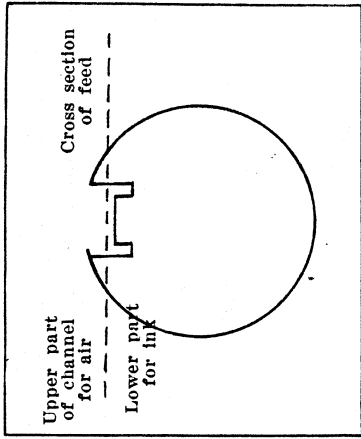

When writing, ink travels down the indentations and lower part of channel to point of nib. Air in turn enters through the airhole in gold nib and travels upward in upper part of channel, replacing amount of ink used, thus insuring a constant, even flow of ink.

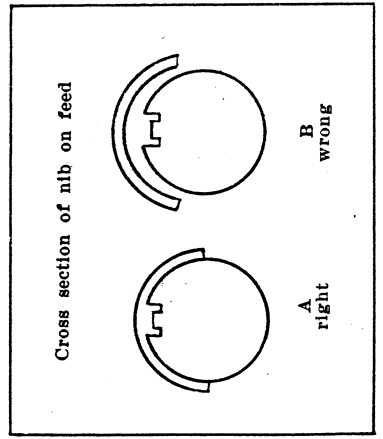

The feed must lie flat and tight against the gold nib. To insure this, heat the forepart of the feed by passing it over a small flame rolling the pen back and forth between the fingers. Heat very slowly to soften the feed. Do not hold in one spot too long, as this may burn the rubber.

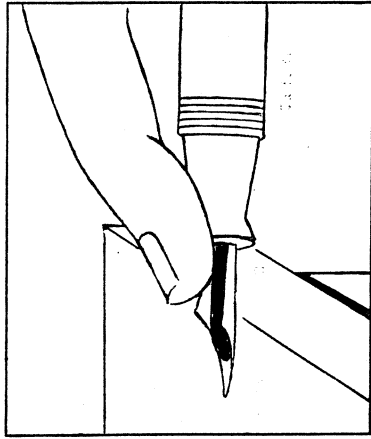

The space between the prongs of Parker gold nibs is made to insure an easy flow of ink. When the space is too wide, ink will flow too freely; when the prongs are closed too tightly, ink will flow only when pressure is exerted.

The gold nib can be adjusted with the thumb nail. To increase flow elevate each prong of gold nib one prong at a time. This produces a spacing. To decrease flow, bend down each prong of gold nib. This closes spacing.

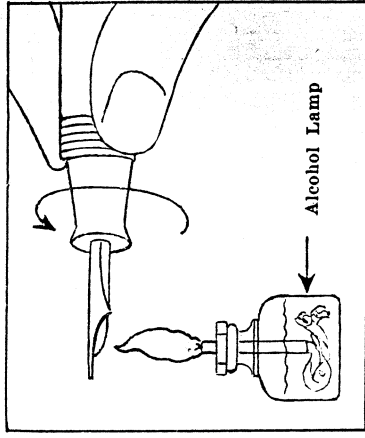
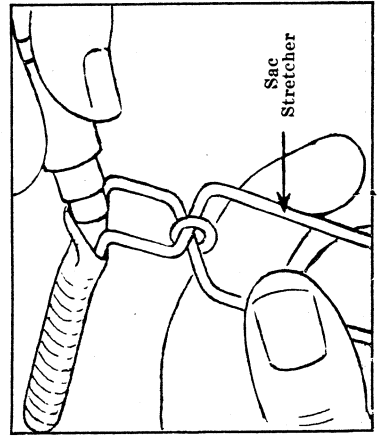

Rest back of gold nib on edge of table, dip forefinger in cold water and rub it firmly back and forth on the nib to cool the feed and prevent its warping. Then dip the pen into cold water. The feed should now fit snugly against the gold nib.

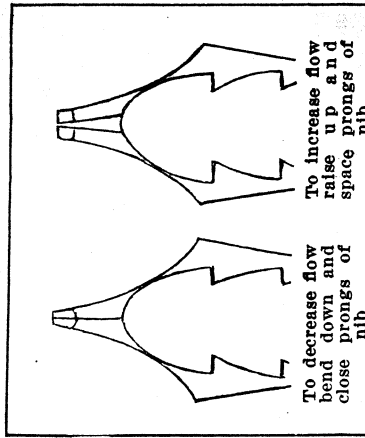

TO ATTACH RUBBER SAC

Put a little shellac on the nipple of section. Spread mouth of sac with the sac spreader and slip the sac onto the nipple. Be careful not to get any shellac in the feed channel.

If rubber sac should be too long, cut off surplus.

Now put a little shellac on that part of section which touches the inside wall of barrel. Insert sac carefully and push section into barrel.

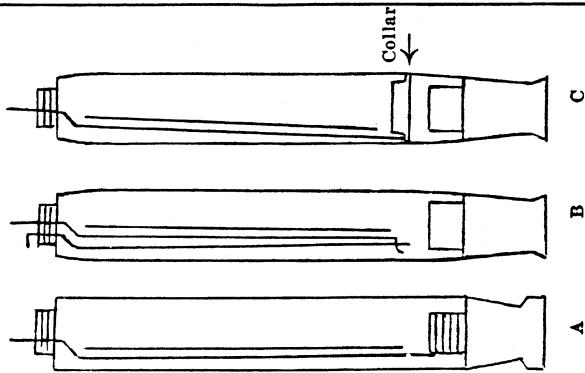

TO INSERT PRESSURE BAR

The pen to be repaired may have one of the following pressure bars:

- A. Double bar for screw section. This is the bar used in the straight shape pens; it rests against section.
- B. Triple bar consisting of 3 pieces. Only a few pens with the triple bar have been shipped.
- C. Double bar for slip section. This is the bar used in the streamlined pens. Inside the barrel is a metal ring or "collar" against which this bar rests. See illustration.

The first two bars have been discontinued. All Parker pens at present are fitted with the double bar for slip section.

Care must be taken that the front end of this bar rests in the collar inside the barrel. The small plate of the pressure bar must face the sac. See illustration.

When inserting pressure bar, bend front end upwards toward the wall of the barrel, so that when you push the bar in, the ink sac will not be telescoped. See illustration.

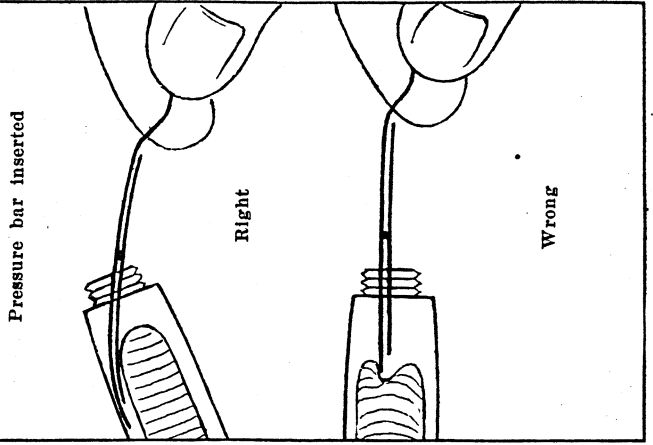

TO FILL PARKER PENS

Unscrew the blind cap on the end of the barrel, and insert pen in a bottle of good fountain pen ink. It is necessary that the nib and feed be completely submerged in the ink. Press button with thumb to expel all air from ink sac. Release thumb from button instantly and let the nib stay in the ink while you count ten. The ink sac should then be filled.

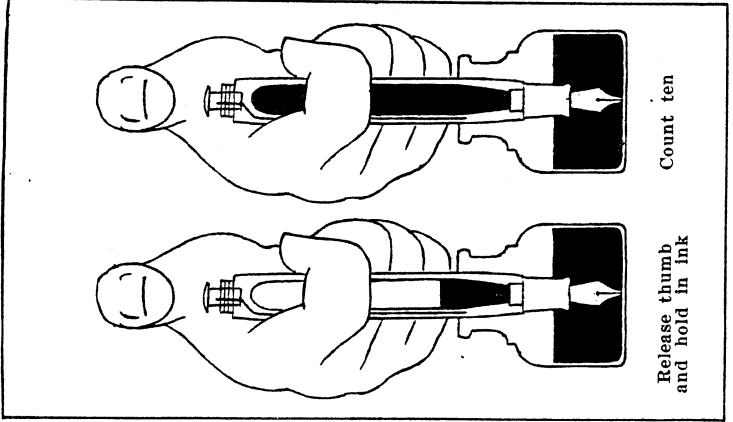

Be sure to explain to the buyer of a Parker Pen that he must give it time to fill. Some people press the filler-button and withdraw the pen almost immediately after releasing pressure on the button and expect the sac to be filled.

To fill the sac completely, the point should remain immersed in ink at least ten seconds. After ten seconds have elapsed withdraw the pen from the ink bottle and with a cloth wipe the gold nib clean. Screw blind cap on the pen; it is now ready for writing.

Although all pens are apparently identical some may require more time to fill than others because of minute variations in the dimensions of feed channel or the degree of elasticity of the rubber sac. Thus some pens may need as much as 15 seconds time to fill completely.

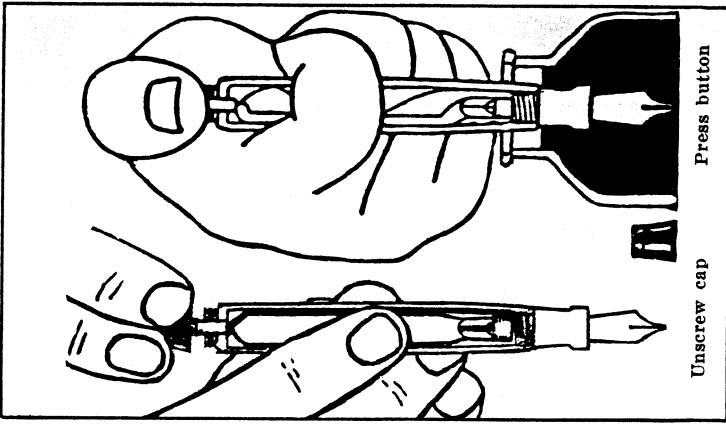

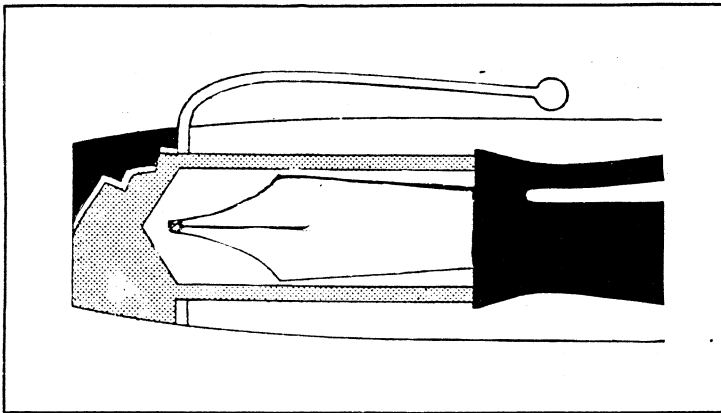

LEAKING

Leaking is a term used in two ways:

(1) If the cap of the pen is not screwed on securely when not in use, the ink may ooze out of the feed and soil the inner wall of the cap. When the user later unscrews the cap, he will get ink on his fingers and complain that his pen "leaks".

The purpose of the cap is to effect a hermetic sealing which makes the escape of ink impossible. To accomplish this, the cap must be screwed on until a click is heard. The click is produced by the sleeve of the inner cap closing tightly over the section.

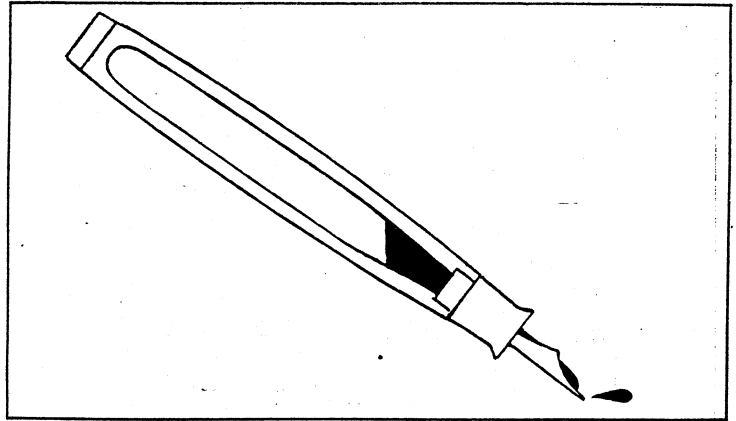

(2) If the sac becomes almost empty, drops of ink may fall from the pen while in use. Such a condition is easily explained. When only one-eighth of the sac is filled with ink, the remaining seven-eighths is filled with air. Air has a higher expansion co-efficient than ink. The warmth of the fingers heats the pen and the air inside the sac; the air expands and forces out too much ink. The result of this process is a "leaky" pen. Nine-tenths of the complaints about "leaking" can be traced to this situation. The remedy is simple—refill the pen with ink.

PROPER CARE OF PARKER FOUNTAIN PENS

The fountain pen is a delicate instrument and should be treated as such. Never fill the pen from an ink bottle that has stood open for some time or from ink which contains sediment, for the dirt particles will clog the fine ink channel in the feed.

In the course of time it is quite natural that even with use of the best ink some small particles of sediment will enter the ink sac and in time obstruct the flow of ink through the channel.

It is, therefore, necessary to clean the fountain pen from time to time in order to keep it in good condition. This cleaning process is very simple. Fill a tumbler with cold water, insert the pen just as for filling, fill the sac with water and expel it again. Repeat this flushing operation four or five times to wash away all sediment in the channel. To insure thorough cleansing of the pen, fill the pen with water and let it stand point down in a tumbler of water overnight. This dissolves and removes all ink crusts.

Never flush with hot water because it ruins the sac and expands the feed.

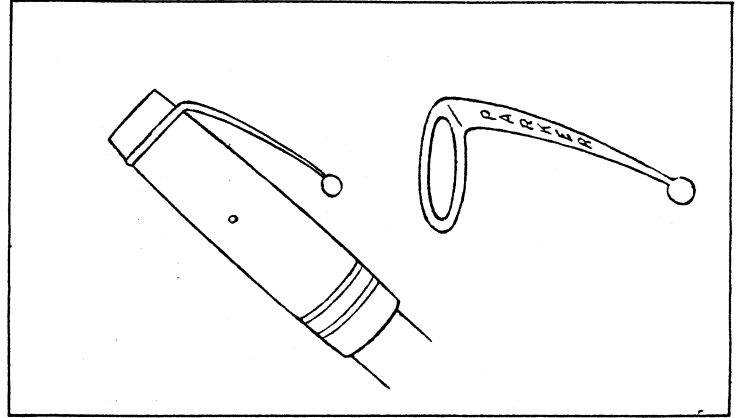

PARKER CLIP

In time, the clip on any fountain pen will lose its strength or spring quality. Here the Parker Duofold has another advantage. When the clip has lost its grip, it is an easy matter to give it new life. Simply remove the clip and bend it to an acute angle. See illustration. When fitted again to the cap, it will be as strong as when the pen was new.

TO REMOVE STAINS ON BARREL

Moisten a piece of tissue paper and put some good tooth paste on it. Rub the soiled part and see how easily the stain is removed.

FEATURES OF THE PARKER PEN

38 YEARS OF PARKER PENS

The Parker Pen Company was founded in 1892. Back of each Parker product is over thirty-eight years of personal experience in the manufacture of fountain pens by Mr. Geo. S. Parker, President of The Parker Pen Company. Parker Duofold pens are in the hands of twenty-six million satisfied users.

NONBREAKABLE

Parker pens are made of permanent which is practically unbreakable. Parker pens have been dropped from airplanes three thousand feet aloft and have landed on cement sidewalks without damage.

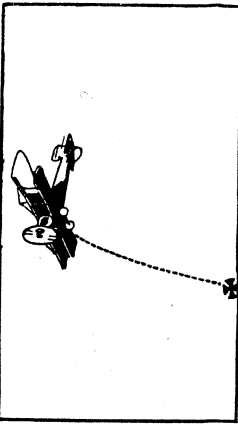
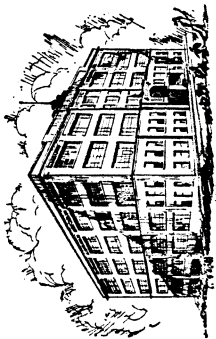

BUTTON FILLER

Parker filler button at top of barrel allows point to reach the bottom of deep ink bottles easily.

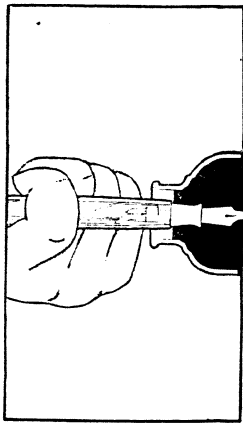

NO CUT IN BARREL

There are no slits disfiguring the pen in the side of the barrel. Ink cannot escape even if the sac should break. "No hole in the wall—no ink on hands or clothes." No side lever to catch on the clothes when removing from pocket.

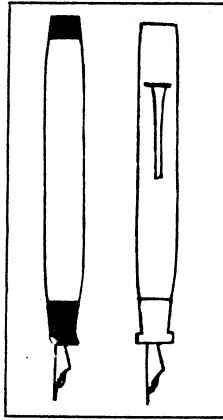

PARKER FEED

Parker's slanted, notched feed prevents "sweating." Feed drains ink back into barrel quickly.

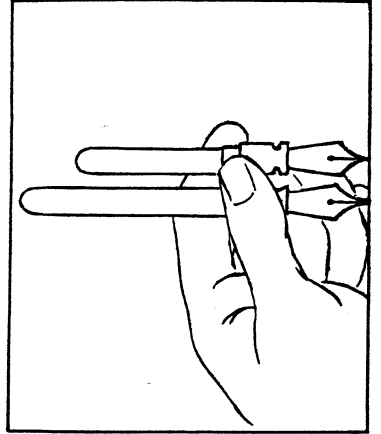

GREATER INK CAPACITY

Parker Duofold's oversize ink capacity is 17.4% greater than the average of other pens, size for size. This gives you 6000 words non-stop writing, with one filling.

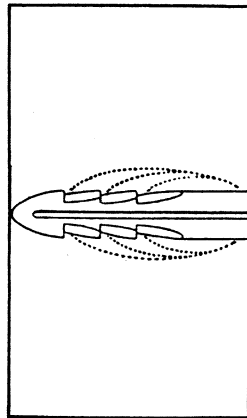

Parker's duo-sleeve safety cap seals the pen hermetically and prevents any loss of ink, even if the pen is carried upside down. When the cap is screwed on the pen, the inner sleeve fits over the gold nib and makes a contact with the section, allowing no ink to escape, provided of course that the cap is screwed on very tightly.

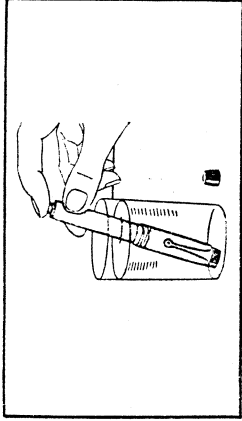

28% LIGHTER THAN RUBBER

Permanite has another advantage in being 28 per cent lighter than hard rubber, which was formerly used in the manufacture of fountain pens. The pen, therefore, feels featherlight in the hand. When writing it glides over the paper with perfect ease.

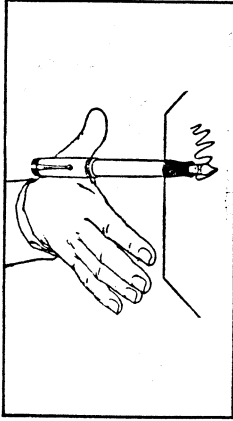

DUOFOLD POINTS

Parker's Heavy Gold nibs are tipped with Tasmanian iridium and are hand ground to a velvet smooth finish. Parker developed a unique plan to insure the perfection of each Parker Duofold nib. Parker pays a bonus to each pen grinder, after all his gold nibs have passed 11 inspections. If a gold nib fails to pass any of the 11 inspections, it is rejected and the pen grinder not only forfeits his bonus but pays a penalty.

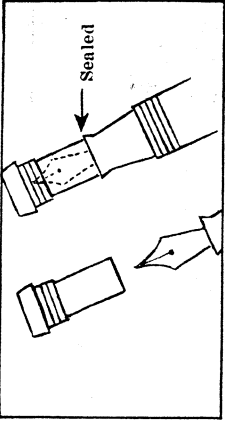
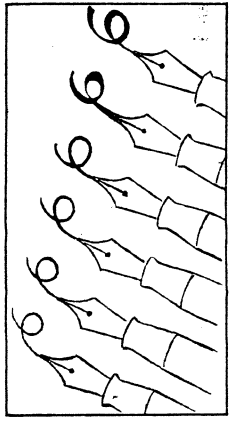

You can demonstrate the leakproof, hermetic sealing in this manner: empty a Parker pen, screw cap on tight, submerge in a tumbler filled with water as shown in the illustration. Press the filler button. Not a single air bubble will appear, proving that the Parker Pen is leakproof.

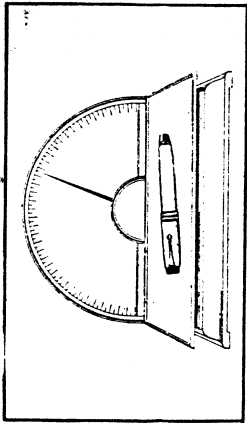

PRESSURELESS TOUCH

One of the greatest achievements in the fountain pen industry is Parker pressureless touch. The physical phenomena of capillary attraction and gravity have been made use of in the construction of the Parker Pen and account for the fact that a tiny globule of ink is fed to the point of the nib and actually touches the paper just an instant before the pen does. The pen can be drawn over the paper without the slightest exertion, thus accomplishing Parker's famous pressureless touch in writing.

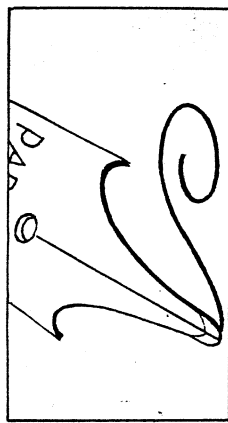

A POINT FOR EVERY HAND

Parker makes many different styles of points—to suit the taste and characteristics of any individual handwriting. Either rigid or flexible points in various gradations of fineness are obtainable.

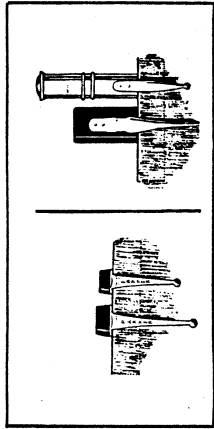

SYMMETRICAL DESIGN

New streamline shape in beautiful symmetry—and pencils to match. Parker pens and pencils fit deeply in pocket, because the clip is fastened on top—not half-way down as on other makes.

2 PENS IN 1

Every owner of a Parker Duofold pen owns half of a Desk Set. In fact, everyone who buys a Parker Pen automatically buys half a desk set. To own a complete desk set, he need buy only a base; it is unnecessary to purchase a special desk pen.

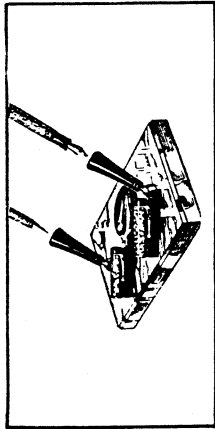

CONVERTIBILITY

All Parker Pens are convertible into pocket or desk pens.

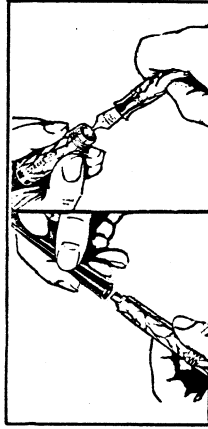

TAPER INCLUDED

The taper to convert pocket pen into desk pen is included with every Parker base.

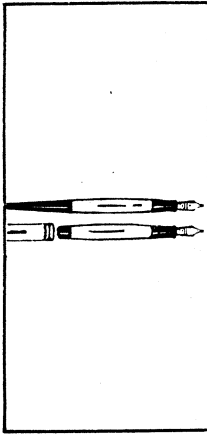
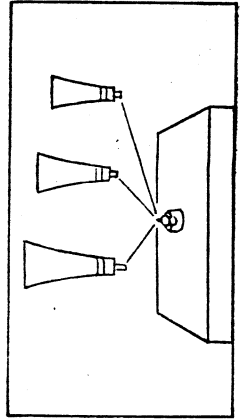

DOUBLE DESK SETS

Parker double desk sets can be supplied either with two pens or with one pen and one pencil.



POCKET PEN-DESK PEN

Convertible in 10 seconds. To change pocket pen to desk pen simply substitute taper for cap.

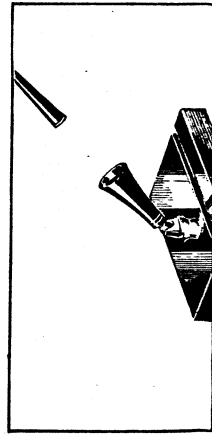

INTERCHANGEABLE

The sockets in Parker desk sets are interchangeable; so any Parker base can be supplied with any Parker pen. Parker sockets are obtainable for pens and pencils.

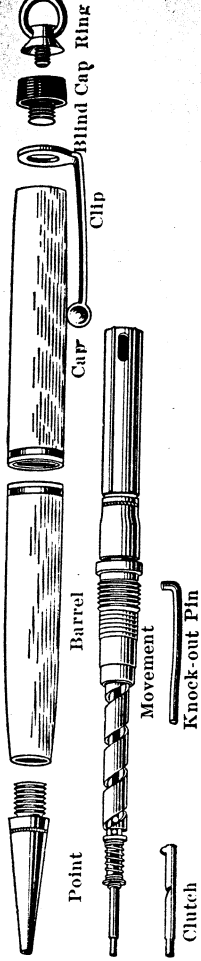

PARKER DUOFOLD PENCIL

The above illustration shows the various parts of the streamlined Parker pencil. A magazine for leads and an eraser is under the cap. To fill the pencil it is not necessary to take it apart; simply insert the lead at the tip.

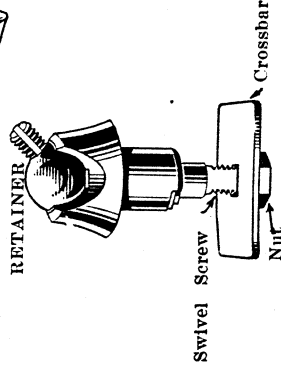
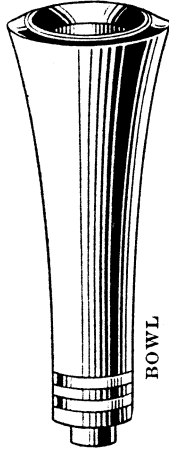
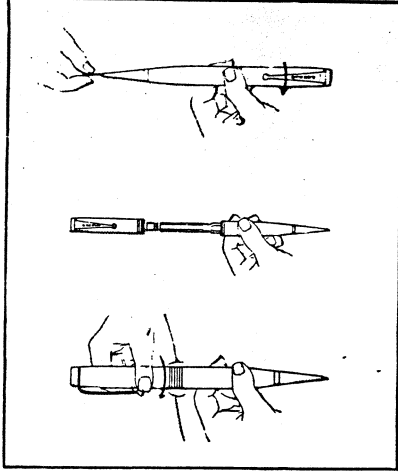

PARKER DESK SET SOCKET

The complete Parker socket consists of Retainer and Bowl (Humidor); the Bowl can be supplied in three sizes: Senior, Junior, and Lady—for either pen or pencil. All bowls are interchangeable.

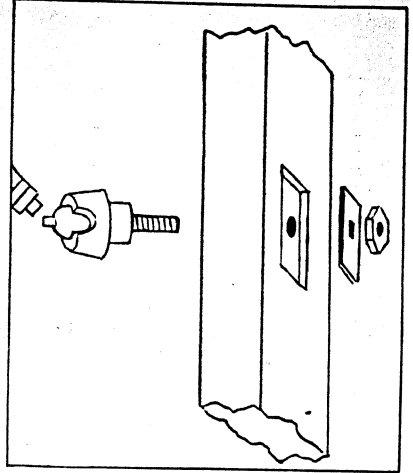

TO ATTACH RETAINER TO BASE

Put lower end with swivel screw through hole in base; slip cross bar into the hole on the underside of base over the swivel screw and screw tight with nut.



To change your Pocket Parker to a Desk Parker—



Remove the pocket cap with clip,

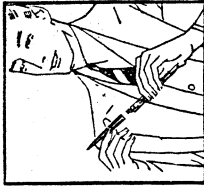

Substitute the tapered tip (free with desk base),

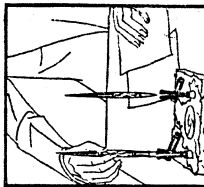

Use your favorite pocket pen as desk pen.

EXPLANATION of the Parker Desk Set in Operation

